

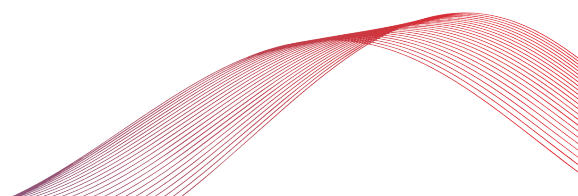

PTM Polarity Tester

User Manual



All information contained herein is believed to be accurate and is subject to change without notice. No responsibility is assumed for its use. © Santec Inc., 2020. All rights reserved.

TABLE OF CONTENTS

| | |
|---------------------------------------|-----------|
| LIST OF FIGURES AND TABLES | v |
| COMPLIANCE | 1 |
| FDA-CDRH Compliance | 1 |
| CSA / IEC Compliance | 1 |
| CE Compliance | 1 |
| GENERAL INFORMATION | 2 |
| PTM Polarity Tester Overview | 2 |
| Applications | 2 |
| Key Features | 3 |
| Included Accessories | 3 |
| Optional Accessories | 3 |
| SAFETY INFORMATION | 4 |
| Safety Markings on the Unit | 4 |
| Classification | 4 |
| Important Safety Information | 5 |
| <i>Laser Hazards</i> | 5 |
| <i>Electrical Hazards</i> | 5 |
| GETTING STARTED | 7 |
| Initial Inspection | 7 |
| Operational Requirements | 7 |
| Product Overview | 8 |
| <i>PTM Front Panel</i> | 8 |
| <i>PTM Rear Panel</i> | 8 |
| OPERATION | 10 |
| Powering Up the Meter | 10 |
| Device Information and Settings | 10 |
| Selecting a Test Plan | 10 |
| Performing a Measurement..... | 12 |
| Visual Fault Locator | 15 |
| PTM WEBPAGE | 16 |
| Dashboard..... | 16 |
| Polarity Types | 17 |
| Settings | 18 |
| <i>Input Strings</i> | 18 |
| <i>Network Settings</i> | 19 |
| <i>Upgrade</i> | 20 |
| Help | 21 |
| About..... | 22 |
| POLARITY TEST SOFTWARE | 24 |
| Establishing Communications | 24 |
| Settings | 25 |

| | |
|--|-----------|
| <i>Saving Results</i> | 25 |
| <i>Custom Polarity Configurations</i> | 25 |
| <i>Custom Fields</i> | 26 |
| PROGRAMMING GUIDE | 27 |
| Establishing Communication | 27 |
| <i>USB</i> | 27 |
| <i>Ethernet</i> | 27 |
| Step-by-step Guide | 27 |
| Note | 28 |
| Commands Lists | 29 |
| MAINTENANCE | 31 |
| Cleaning the Unit | 31 |
| Cleaning the Output and Receive Connectors | 31 |
| STORAGE AND SHIPPING | 32 |
| Returning Instruments to Santec | 32 |
| Contact Information | 32 |
| SPECIFICATIONS | 33 |

LIST OF FIGURES AND TABLES

Figure 1: PTM Polarity Tester 2

Figure 2: Front view of a 24 channel PTM 8

Figure 3: Rear view of a PTM 9

Figure 4: PTM *Setup* page 10

Figure 5: PTM *Test Plan Information* page – choosing a polarity 11

Figure 6: PTM *Test Plan Information* page – *Discover* function 11

Figure 7: PTM *Test Plan Information* page – deleting a custom polarity 12

Figure 8: PTM *Measurement* page 12

Figure 9: Picture of a PTM test setup 13

Figure 10: Testing a 24 fiber MPO cable with the PTM 14

Figure 11: PTM *Visual Fault Locator* page 15

Figure 12: PTM *Visual Fault Locator* page – *Settings* pop-out menu 15

Figure 13: PTM webpage – *Dashboard* tab 16

Figure 14: PTM webpage – *Polarity Types* tab 17

Figure 15: PTM webpage – managing a custom polarity profile 18

Figure 16: PTM webpage – *Input Strings* tab 19

Figure 17: PTM webpage – *Network Settings* tab 20

Figure 18: PTM webpage – *Upgrade* tab 21

Figure 19: PTM webpage – *Help* tab 22

Figure 20: PTM webpage – *About* tab 23

Figure 21: Polarity Test Software – *SETTINGS* tab 24

Figure 22: Polarity Test Software – *Excel Export Settings* 25

Figure 23: Polarity Test Software – custom polarity configuration window 25

Table 1: Safety symbols 4

Table 2: PTM laser specifications 5

Table 3: Environmental requirements 7

Table 4: Detailed description of the PTM rear panel components (see Figure 3) 9

Table 5: Detailed description of Figure 9 13

Table 6: Description of HID input string SCPI commands 19

Table 7: Standard SCPI required commands list 29

Table 8: PTM commands list 30

Table 9: PTM optical and electrical specifications sheet 33

Table 10: PTM mechanical and environmental specifications sheet 33

1

COMPLIANCE

FDA-CDRH Compliance

Under the US Food and Drug Administration (FDA) Center for Devices and Radiological Health (CDRH), the unit complies with the Code of Federal Regulations (CFR), Title 21, Subchapter J, which pertains to laser safety and labeling. See following link for more information:

- <http://www.accessdata.fda.gov/scripts/cdrh/cfdocs/cfcfr/CFRSearch.cfm?CFRPartFrom=1000&CFRPartTo=1050>

CSA / IEC Compliance

The unit complies with certain standards of the Canadian Standards Association (CSA) and the International Electrotechnical Commission (IEC).

The unit falls in the Installation Category (Overvoltage Category) II under IEC 664. IEC 664 relates to impulse voltage levels and insulation coordination. The category is defined as: local level, appliances, portable equipment, etc., with smaller transient overvoltages than Installation Category (Overvoltage Category) III.

The unit falls in the Pollution Degree 2 category under IEC 1010-1 and CAN/CSA-C22.2 No. 1010.1. The IEC standard on Safety Requirements for Electrical Equipment for Measurement, Control, and Laboratory Use relates to insulation coordination. The CSA standard is on Safety Requirements for Electrical Equipment for Measurement Control, and Laboratory Use, Part I: General Requirements. The Pollution Degree 2 category is defined as follows: “Normally only non-conductive pollution occurs. Occasionally, however, a temporary conductivity caused by condensation must be expected.”

CE Compliance

Electronic test equipment is subject to the EMC Directive in the European Union. The EN61326 standard prescribes both emission and immunity requirements for laboratory, measurement, and control equipment. This unit has undergone extensive testing according to the European Union Directive and Standards.

2

GENERAL INFORMATION

PTM Polarity Tester Overview

The PTM Polarity Tester is an easy-to-use instrument specifically designed to check the polarity of fiber-optic cable assemblies. The PTM can be built with up to 288 channels in one chassis or expanded to 432 if needed.



Figure 1: PTM Polarity Tester

The PTM is equipped with a touchscreen interface to allow for one touch testing of typical pre-programmed types A, B, C and custom profiles. Remote operation is possible via USB or Ethernet. Testing can be performed with SANTEC's new XN1 Server or with the included Polarity Test Software which allows saving results to Excel.

The Visual Fault Locator (VFL) mode enables easy manual identification of any possible damaged or crossed fiber.

Applications

- MTP/MPO cable assembly mapping
- Multi-fiber assemblies
- Complex network mapping
- QC inspection

Key Features

- Fast Pass/Fail results (12 channels in under 2s)
- Built-in recognition of common polarity types A, B and C
- Easy-to-configure custom polarities including *Discover* function
- Up to 288 channels in one chassis
- Touchscreen display and operation
- “Non-contact” MTP/MPO testing
- XN1 Server ready
- Test results can be saved in *Microsoft Excel* via SANTEC’s Polarity Test Software

Included Accessories

- Polarity Test Software and drivers
- USB A to USB B cable (1.8m)
- Ethernet cable (1.8m)
- AC power cord (2m)

Optional Accessories

- NCA-MTP-12: MTP/MPO centered key, non-contact adapter
- Barcode scanner
- Rackmount kit

3

SAFETY INFORMATION



To avoid situations that could result in serious injuries or death, always observe the following precautions.

The safety instructions must be observed whenever the unit is operated, serviced, or repaired. Failure to comply with any of these instructions or with any precaution or warning contained in the user manual is in direct violation of the standards of design, manufacturing, and intended use of the unit. Santec Inc. assumes no liability for the customer’s failure to comply with any of these safety requirements.

Safety Markings on the Unit

See Table 1 for symbols and messages that can be marked on the unit. Observe all safety instructions that are associated with a symbol.

Table 1: Safety symbols

| | |
|---|--|
|  | <p>Laser radiation may be present. Refer to the user manual for instructions on handling and operating the unit safely. Avoid looking into any ports near which this symbol appears.</p> |
|  | <p>Frame or chassis terminal for electrical grounding within the unit.</p> |
|  | <p>Protective conductor terminal for electrical grounding to the earth.</p> |
| <p>WARNING</p> | <p>Procedure can result in serious injury or loss of life if not carried out in proper compliance with all safety instructions. Ensure that all conditions necessary for safe handling and operation are met before proceeding.</p> |
| <p>CAUTION</p> | <p>Procedure can result in serious damage to or destruction of the unit if not carried out in compliance with all instructions for proper use. Ensure that all conditions necessary for safe handling and operation are met before proceeding.</p> |

Classification

The PTM consists of an exposed metal chassis that is connected directly to earth via a power cord and is therefore classified as a Class 1 instrument.

The laser (or lasers) contained in the BR1 is (are) Class 2M laser(s) as specified under the international standard IEC 60825-1 Ed. 3.0 b:2014 and ANSI Z136.1-2014. See Table 2 for laser specifications.



Table 2: PTM laser specifications

| Parameter | Specification |
|-------------------|---------------|
| Wavelength (nm) | 650 |
| Output Power (mw) | Less than 1 |
| Class | 2M |

Important Safety Information

Laser Hazards

Warning



- Never look directly into the end of an optical cable connected to an optical output device that is operating. Laser radiation is invisible and direct exposure can severely injure the human eye.

Electrical Hazards

Warning



- Some of the circuits are powered whenever the unit is connected to the AC power source (line power). To ensure that all circuits are powered off, disconnect the power cord from either the power inlet on the unit's rear panel or from the AC line-power source (receptacle). The power cord must always be accessible from one of these points. If the unit is installed in a cabinet, the operator must be able to disconnect the unit from the line power by the system's line-power switch.
- Use only the type of power cord supplied with the unit. If you need to replace a lost or damaged cord, make sure to replace with a power cord of the same type.
- Connect the power cord only to a power outlet equipped with a protective earth contact. Never connect to an extension cord or any receptacle that is not equipped with this feature.
- If using a voltage-reducing autotransformer to power the unit, ensure that the common terminal connects to the earthed pole of the power source.

- Do not interrupt the protective earth grounding. Such action can lead to a potential shock hazard that can result in serious personal injury. Do not operate the unit if an interruption to the protective grounding is suspected.
- Do not operate the unit when its cover or panels have been removed.
- To prevent potential fire or shock hazard, do not expose the unit to any source of excessive moisture.
- Do not use the unit outdoor.
- Operating the unit in the presence of flammable gases or fumes is extremely hazardous.
- If the equipment is used in a manner not specified by the manufacturer, the protection provided by the equipment may be impaired. Only technicians authorized by Santec Inc. should carry out repairs. In addition to voiding the warranty, opening the unit (even when unplugged) can expose you to potential shock hazards.
- Some of the unit's capacitors can be charged even when the unit is not connected to the power source.
- Do not perform any operating or maintenance procedure that is not described in the user manual.

4

GETTING STARTED

Caution



- To avoid injury or death, always observe the precautions listed in SAFETY INFORMATION on page 4.

This manual contains complete operating instructions for safe and effective operation of the PTM Polarity Tester. It is recommended that users of the PTM familiarize themselves with contents of this manual before using the instrument.

The inspection report and a description of any customer-requested information may be found in the calibration document envelope included with the instrument.

Initial Inspection

Warning



- To avoid electrical shock, do not initialize or operate the unit if it bears any sign of damage. Ensure that the unit and any devices or cords connected to it are properly grounded.

- ✓ Inspect the package and contents for signs of damage.
- ✓ Ensure all contents are included.
- ✓ Read the user manual thoroughly and become familiar with all safety symbols and instructions to ensure that the unit is operated and maintained safely.
- ✓ If the initial inspection reveals any damage or missing components, immediately notify Santec Inc. and if necessary, the carrier.

Operational Requirements

For the unit to meet the warranted specifications, the operating environment must meet the conditions outlined in Table 3.

Table 3: Environmental requirements

| Parameter | Specification |
|-----------|---------------|
|-----------|---------------|

| | |
|-------------|--|
| Altitude | Up to 2000m |
| Temperature | 0 to 40°C |
| Humidity | Up to 95% RH (0 to 40°C) |
| Voltage | Main supply voltage fluctuations must not exceed $\pm 10\%$ of the nominal voltage |

Product Overview

PTM Front Panel

A front view of the PTM meter is shown in Figure 2. It features a touchscreen which displays information such as results, VFL, test plans and setup.

The MTP/MPO output and receive panel is located on the front of the unit. The connectors are 12 fiber MTP/APC male (SM) for the output and 12 fiber MTP/PC male (MM) for the receive. This allows the PTM to test both SM and MM assemblies.

When testing assemblies with more than 12 fibers, fanout cables are required to connect from the PTM output/receive to the DUT (Figure 10).



Figure 2: Front view of a 24 channel PTM

PTM Rear Panel

A rear view of the PTM meter is shown in Figure 3. See Table 4 for a detailed description.



Figure 3: Rear view of a PTM

Table 4: Detailed description of the PTM rear panel components (see Figure 3)

| Item # | Description |
|--------|--|
| 1 | LAN/Reset <ul style="list-style-type: none"> • Press once: reset network settings |
| 2 | Ethernet port <ul style="list-style-type: none"> • Connection to LAN |
| 3 | USB B port <ul style="list-style-type: none"> • Connection to PC |
| 4 | USB A ports <ul style="list-style-type: none"> • Connections to peripherals such as barcode scanner |
| 5 | IO switch <ul style="list-style-type: none"> • On/off toggle |
| 6 | Power input <ul style="list-style-type: none"> • Contains user-replaceable fuse |

5

OPERATION

Powering Up the Meter

To power up the meter:

1. Verify that the power switch is set to the “off” position (O). Connect the meter to an AC power supply using the power cord provided.
2. Toggle the power switch to the “on” position (I). The SANTEC logo will flash on the screen during the unit’s initialization.

Device Information and Settings

Swipe left to access the *Setup* page (farthest page to the right, see Figure 4). This page will display information about the unit and its connectivity status.

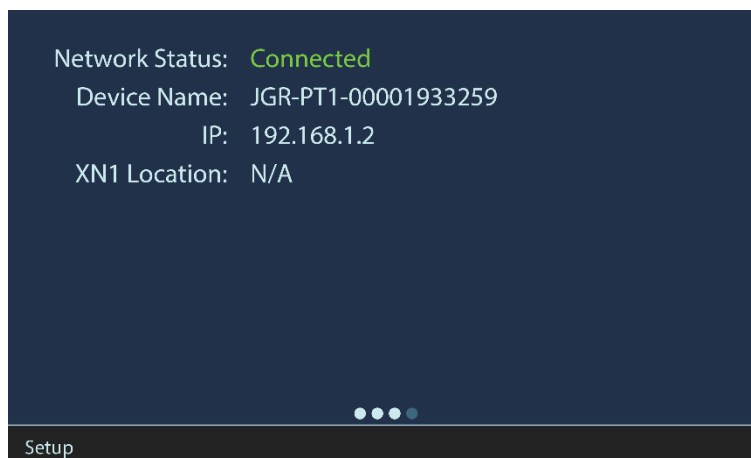

Figure 4: PTM Setup page

Selecting a Test Plan

Swipe right to access the *Test Plan Information* page (Figure 5).

Scan an XN1 test plan barcode while on this screen to load the plan onto the PTM. Please refer to the *XN1 Server User Manual* for more information.

To operate the PTM without a test plan, tap on one of the saved polarity configurations. The *Auto* profile will automatically detect which saved configuration matches (if any) the device under testing (DUT).

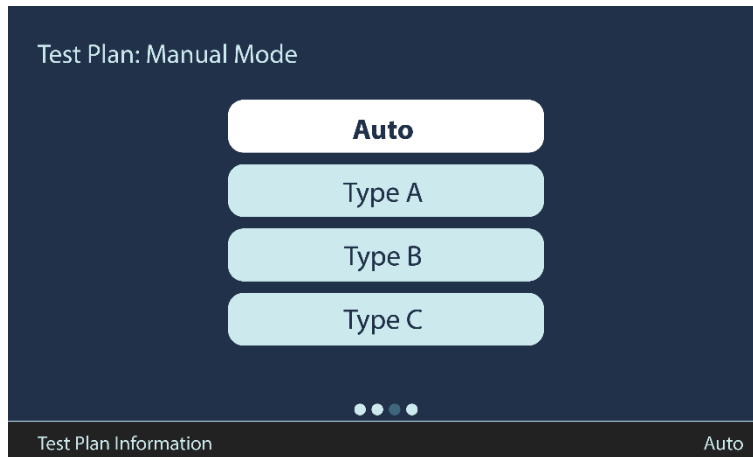

Figure 5: PTM *Test Plan Information* page – choosing a polarity

Press and move up/down to scroll through the menu. To create a new polarity type using the front panel touchscreen, connect a known polarity type cable to the PTM and tap on *Discover* (Figure 6).

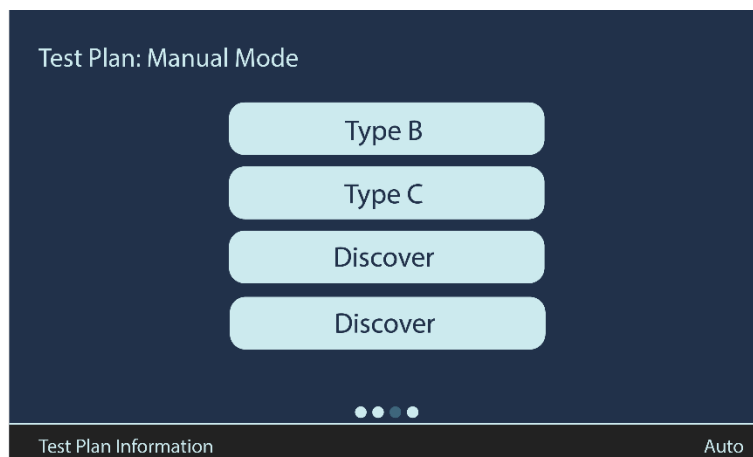

Figure 6: PTM *Test Plan Information* page – *Discover* function

To delete a saved polarity, tap on the X next to one of the custom profiles (Figure 7).

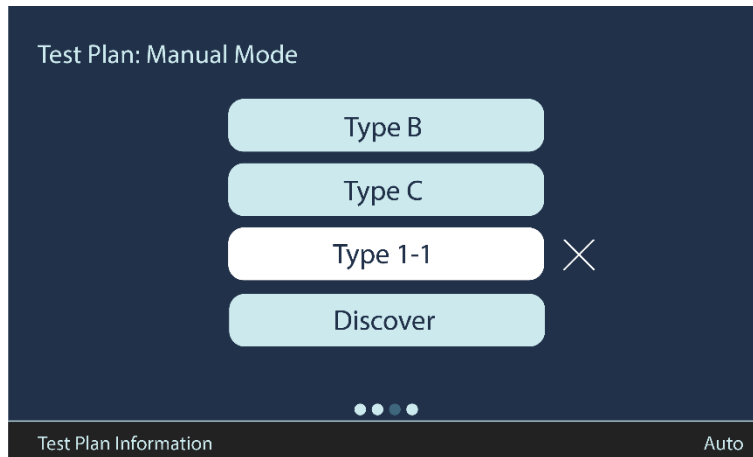

Figure 7: PTM Test Plan Information page – deleting a custom polarity

Performing a Measurement

Swipe right to access the *Measurement* page (Figure 8).



Figure 8: PTM Measurement page

Connect your device (see Figure 9 and Table 5) then tap in the main window area to perform a measurement.

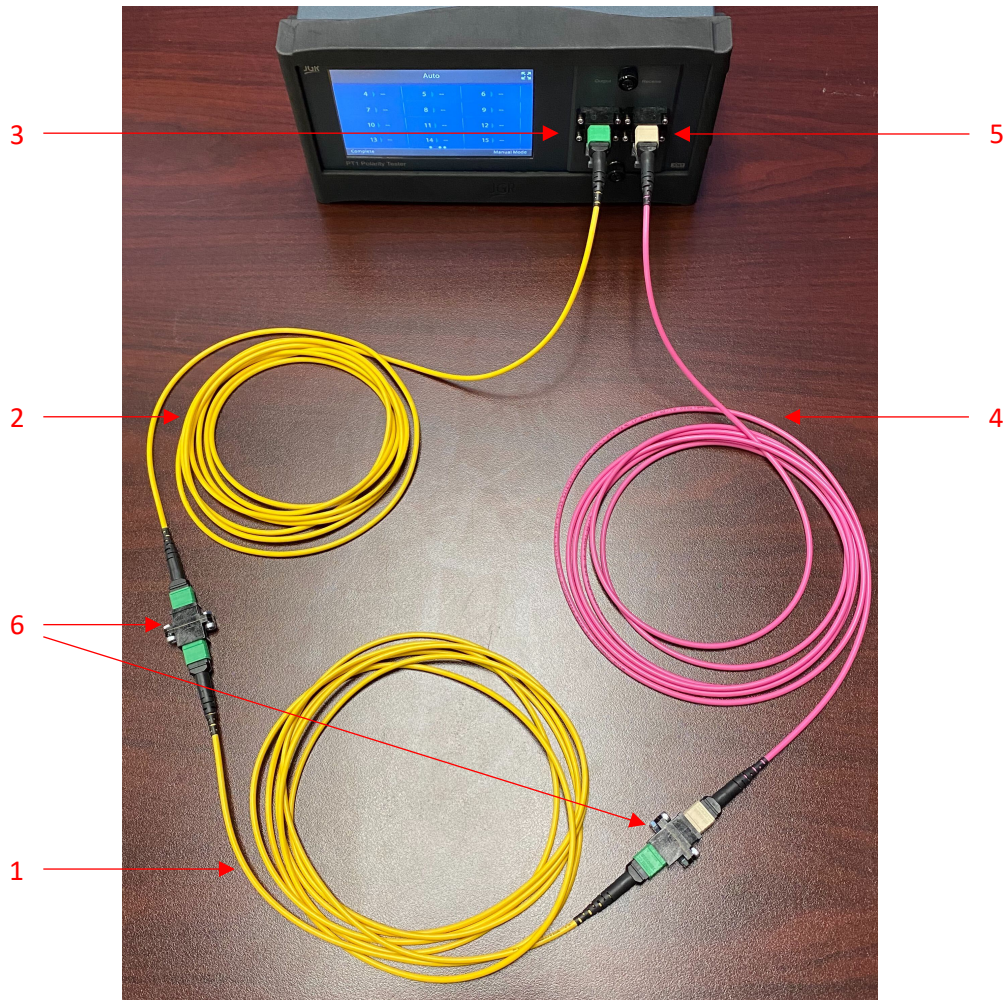

Figure 9: Picture of a PTM test setup

Table 5: Detailed description of Figure 9

| Item # | Description |
|--------|--|
| 1 | DUT: SM 12 fiber MPO cable <ul style="list-style-type: none"> side A (output): MPO/APC (male) side B (receive): MPO/APC (female) |
| 2 | Output cable: SM 12 fiber cable (polarity type A) <ul style="list-style-type: none"> PTM side: MPO/APC (female) DUT side: MPO/APC (female) |
| 3 | PTM output |
| 4 | Receive cable: MM 12 fiber cable (polarity type A) <ul style="list-style-type: none"> PTM side: MPO/PC (female) DUT side: MPO/APC (male) |
| 5 | PTM receive |
| 6 | Non-contact MPO mating adapters (NCA-MTP-12) |

Notes:

- By using SM output and MM receive cables, the DUT can be either SM or MM. The PTM can accurately measure polarity as long as the direction of light is going from a core of size d_1 to a core of size d_2 where $d_1 \leq d_2$
- The non-contact adapters (NCA) are ideal for high volume testing as they negate the risk of contamination or damage during mating. No connector end-face inspection is required. The NCA should be used between the output/receive cables and the DUT.
- When testing DUTs with more than 12 fibers, fanouts are required for the output and receive cables. For an example, see Figure 10.

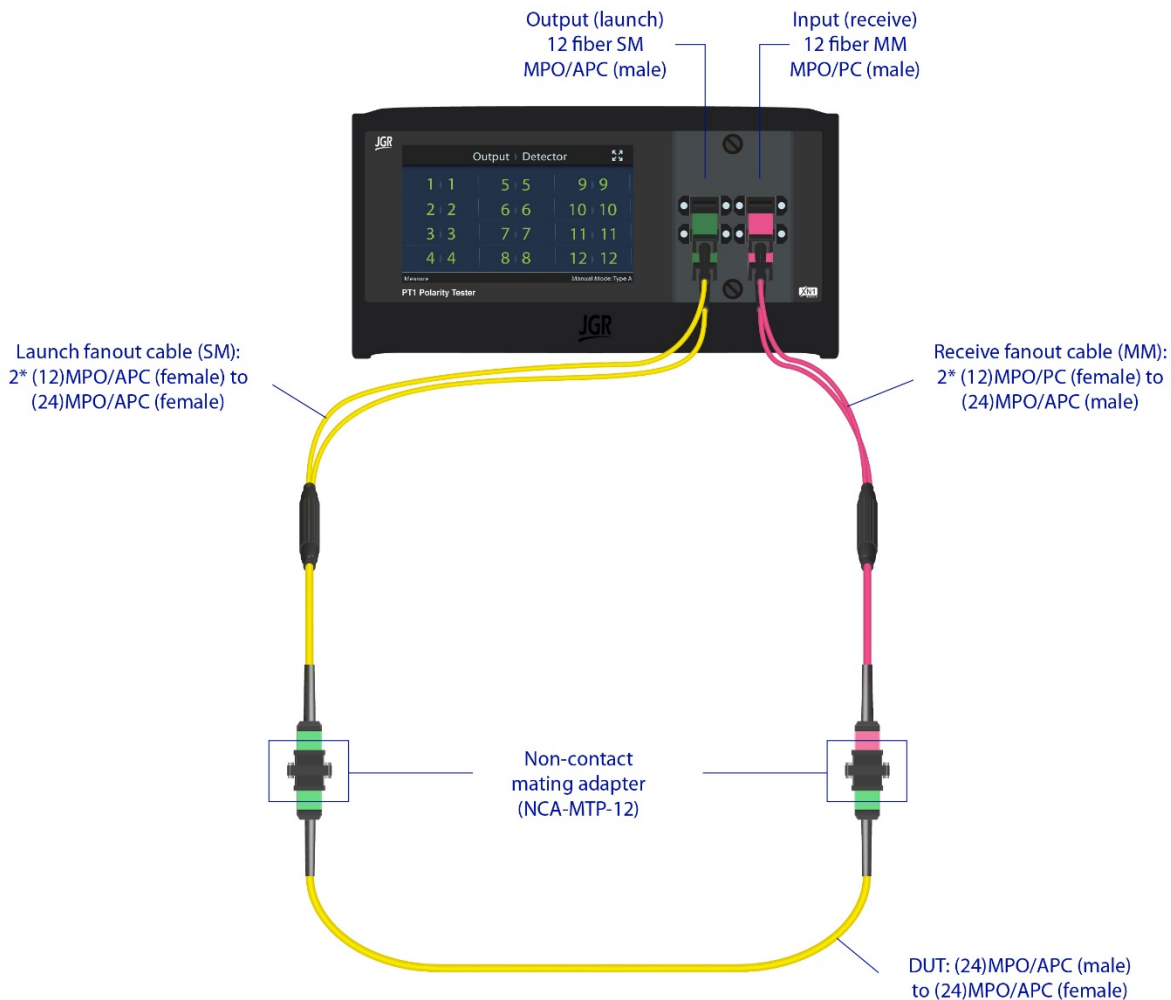

Figure 10: Testing a 24 fiber MPO cable with the PTM

Visual Fault Locator

Swipe right to access the Visual Fault Locator (VFL) page (Figure 11). Tap on a channel to activate the corresponding red light source.



Figure 11: PTM Visual Fault Locator page

Press and hold to open the VFL Settings pop-out menu (Figure 12).

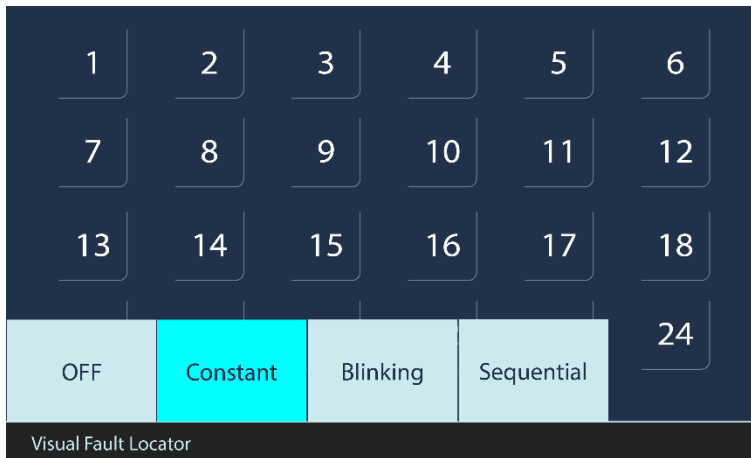

Figure 12: PTM Visual Fault Locator page – Settings pop-out menu

6

PTM Webpage

To access the PTM webpage, connect the meter to a network and on any computer or tablet on the same network, open a web browser (recommended: *Google Chrome* or *Firefox*) and enter the PTM's IP address (see Device Information and Settings on page 10) in the URL bar.

Dashboard

Access the *Dashboard* tab to view or edit the device name (Figure 13).

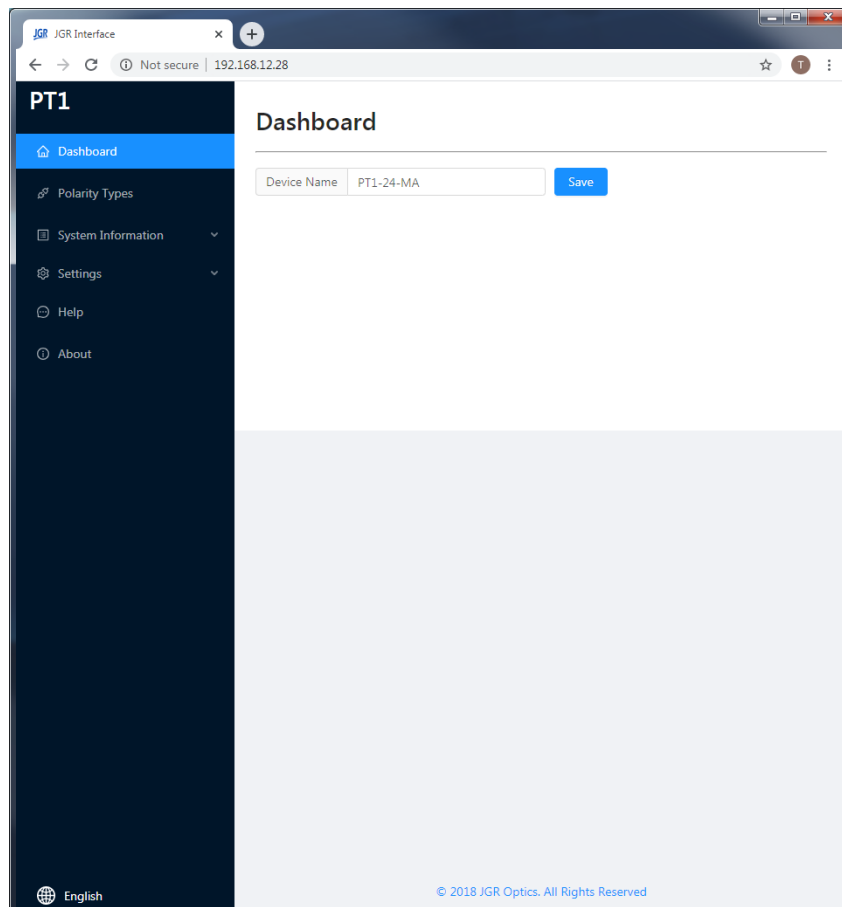

Figure 13: PTM webpage – *Dashboard* tab

Polarity Types

Go to the *Polarity Types* tab to view or edit custom polarity profiles.

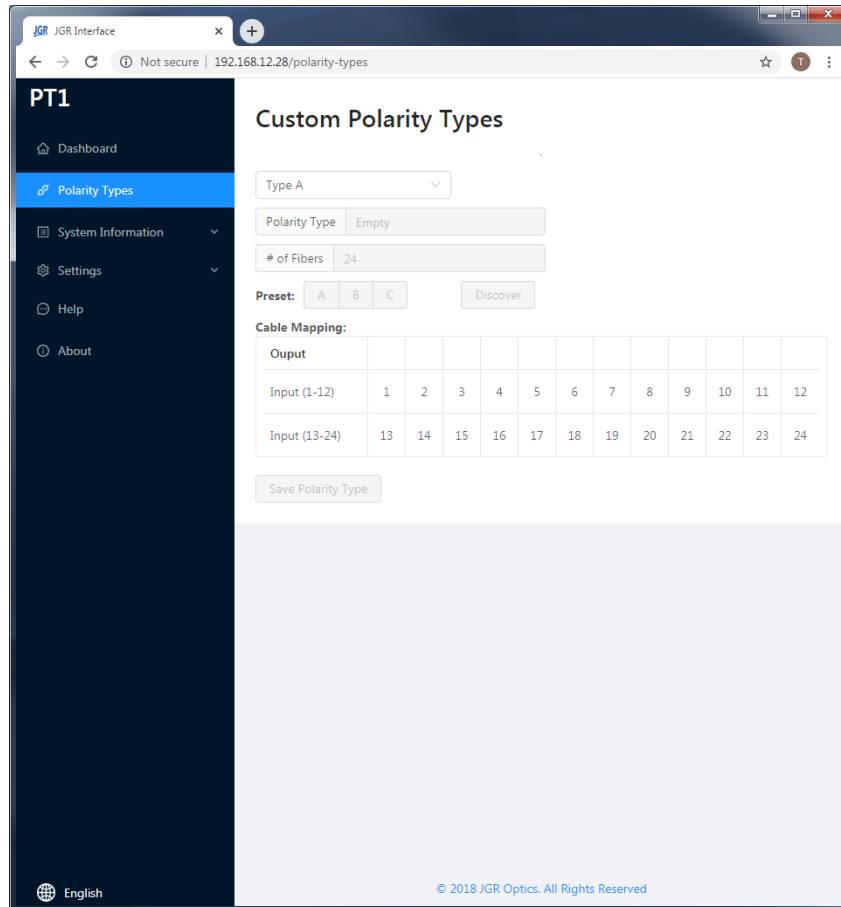
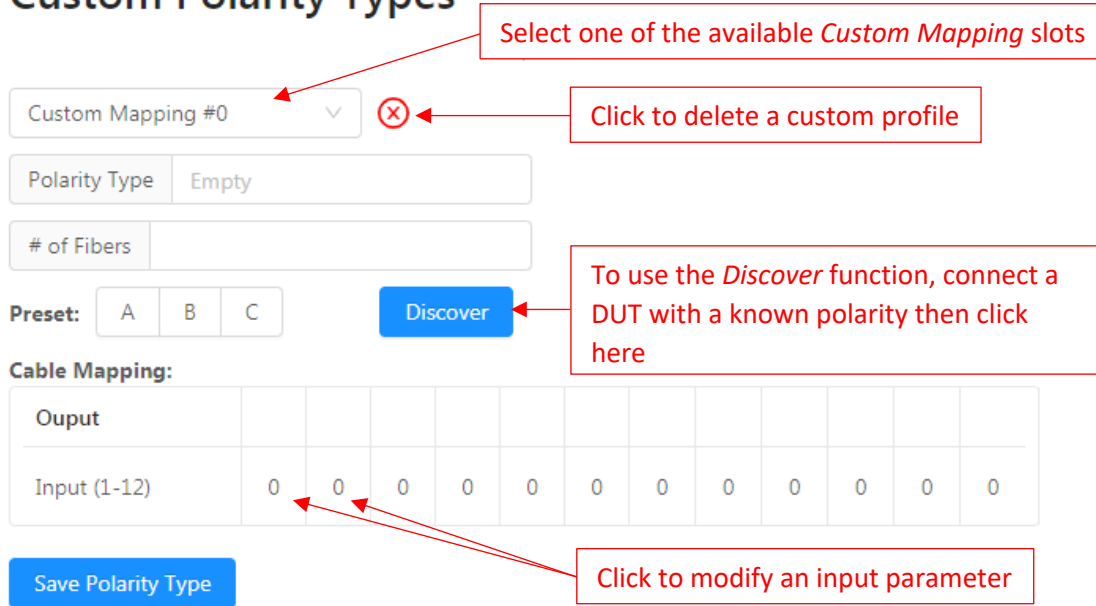

Figure 14: PTM webpage – *Polarity Types* tab

See Figure 15 for additional information on managing custom profiles.

Custom Polarity Types



Select one of the available *Custom Mapping* slots

Click to delete a custom profile

To use the *Discover* function, connect a DUT with a known polarity then click here

Click to modify an input parameter

| Output | | | | | | | | | | | | | |
|--------------|---|---|---|---|---|---|---|---|---|---|---|---|---|
| Input (1-12) | 0 | 0 | 0 | 0 | 0 | 0 | 0 | 0 | 0 | 0 | 0 | 0 | 0 |

Figure 15: PTM webpage – managing a custom polarity profile

Settings

Click on the *Settings* tab to expand.

Input Strings

You can assign a Human Interface Device (HID) input string from the *Settings > Input Strings* tab (Figure 16). Note: the HID must be USB 2.0 or higher and an XN1 test plan must be loaded. See Table 6 for a list of commands that can be assigned.

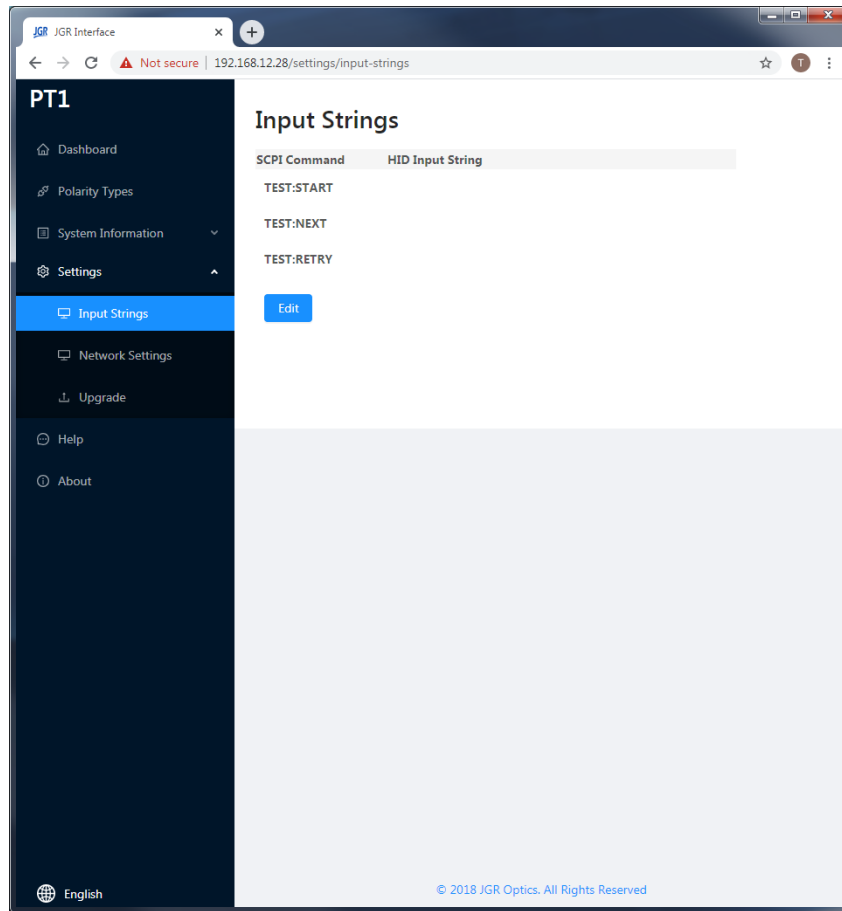

Figure 16: PTM webpage – *Input Strings* tab

Table 6: Description of HID input string SCPI commands

| SCPI Command | Description |
|--------------|---|
| TEST:START | With an XN1 test plan loaded, start a test. |
| TEST:NEXT | After performing an XN1 test plan, save results to server and prepare for the next DUT. |
| TEST:RETRY | After performing an XN1 test plan, retry the current plan. |

Network Settings

You can view, edit or reset the network settings of the PTM from the *Settings > Network Settings* tab (Figure 17).

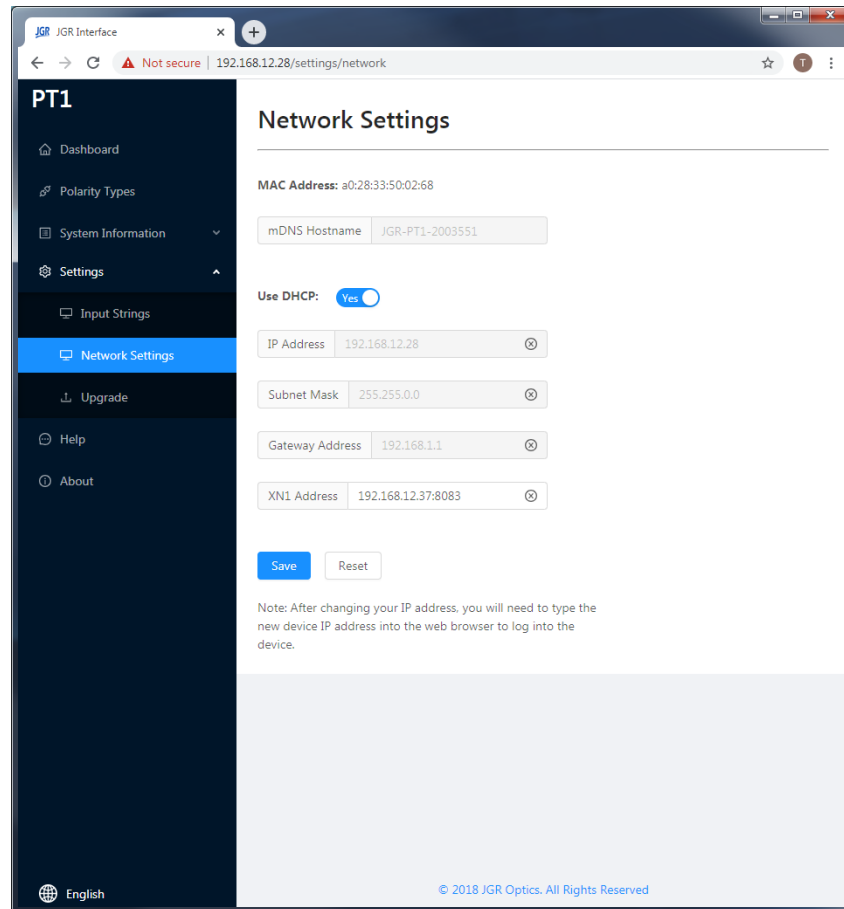

Figure 17: PTM webpage – *Network Settings* tab

Upgrade

Go to *Settings > Upgrade* to view the version of, upgrade or re-install the firmware of the PTM (Figure 18). Please contact support@jgroptics.com before performing a firmware upgrade for additional instructions.

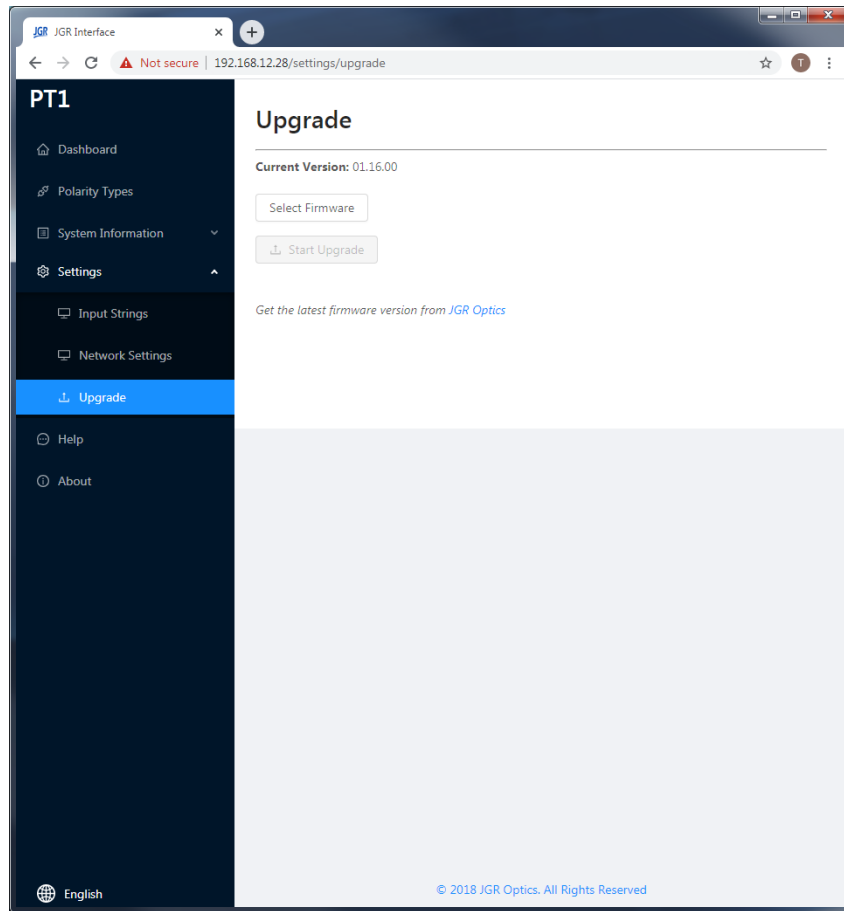

Figure 18: PTM webpage – *Upgrade* tab

Help

Click on the *Help* tab (Figure 19) for the website technical support and sales contact forms as well as a link to the software downloads page.

Alternatively, email support@jgropitics.com for technical support or info@jgropitics.com for sales and other inquiries.

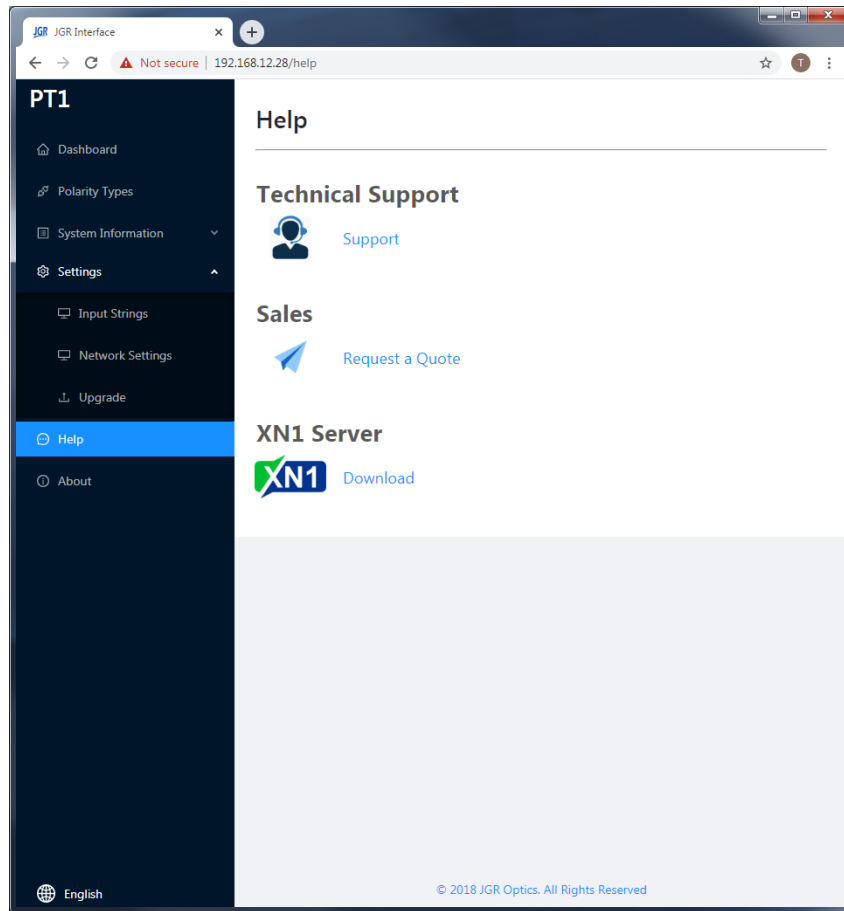

Figure 19: PTM webpage – *Help* tab

About

The *About* tab (Figure 20) displays the unit's firmware version, model and serial number. *Advanced* mode is reserved for SANTEC technicians and SANTEC-approved service centers.

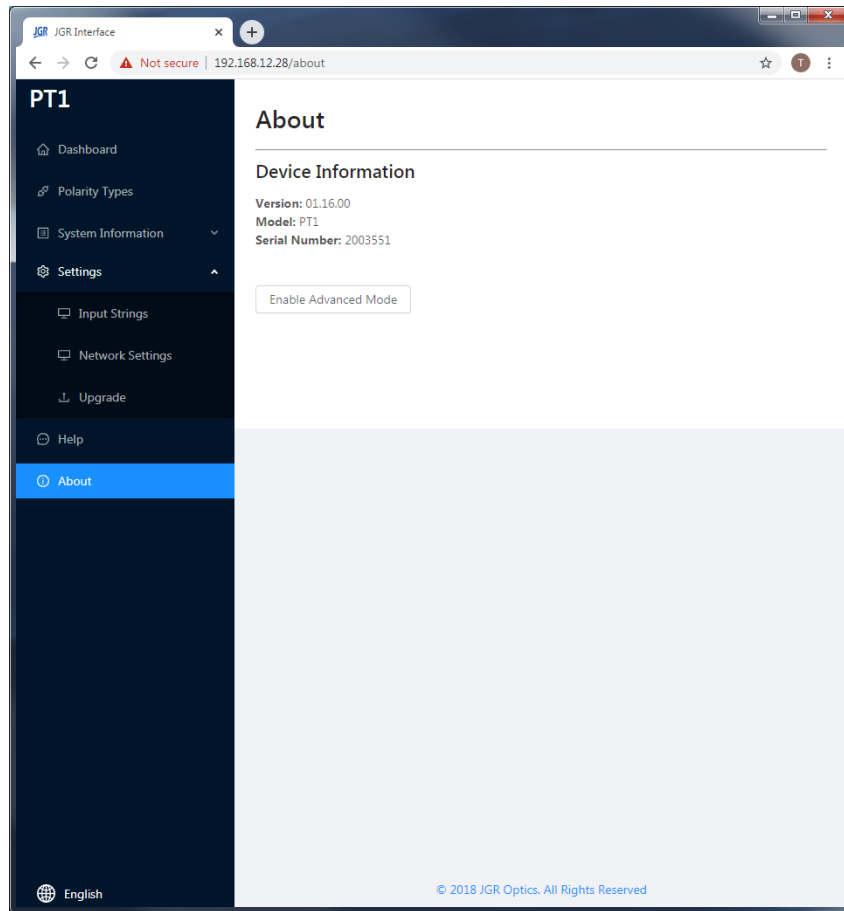

Figure 20: PTM webpage – *About* tab

7

Polarity Test Software

SANTEC’s free Polarity Test Software is an easy way to control the PTM. Please visit SANTEC’s website or contact support@jgroptics.com for the latest version.

Establishing Communications

1. Connect the PTM via USB to the PC or via Ethernet to the same network as the PC.
2. Launch the software.
3. Go to the *SETTINGS* tab (Figure 21).
 - a. If connected by USB, click on *Configure* and set *PTM on USB* to 1.
 - b. If connected by Ethernet, click *Add Ethernet* and enter the PTM’s IP address as displayed on its front panel touchscreen. The default port is 5025. Click *Test* and if successfully connected, click *Add*.
4. Click *Save*.

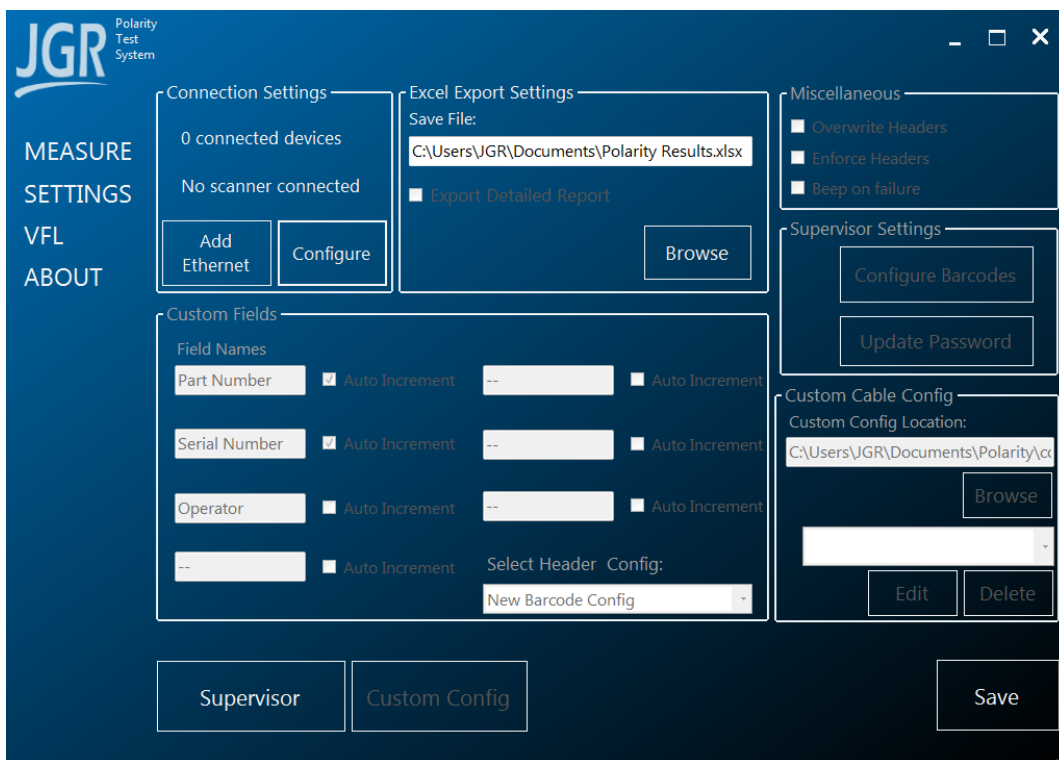

Figure 21: Polarity Test Software – *SETTINGS* tab

Settings

From the *SETTINGS* tab (Figure 21), click on the *Supervisor* button to modify any of the settings. There is no password by default.

Saving Results

Every time a polarity test is performed, the results are automatically saved to Excel. Click on *Browse* to set the save file path. The detailed report includes the full list of output/input results for each channel. See Figure 22.

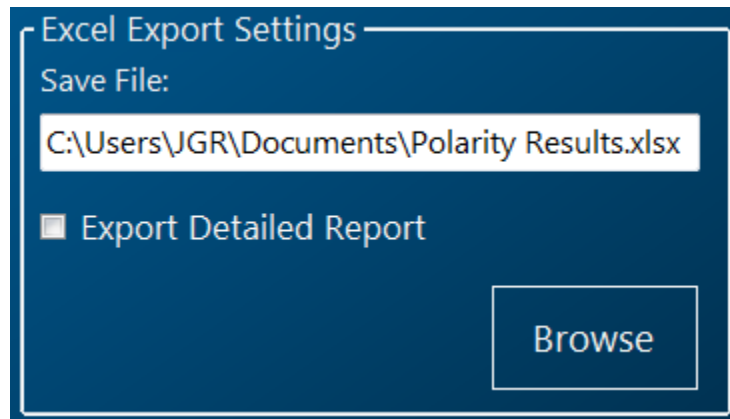

Figure 22: Polarity Test Software – *Excel Export Settings*

Custom Polarity Configurations

Click on *Custom Config* to open the custom polarity configuration window (Figure 23).

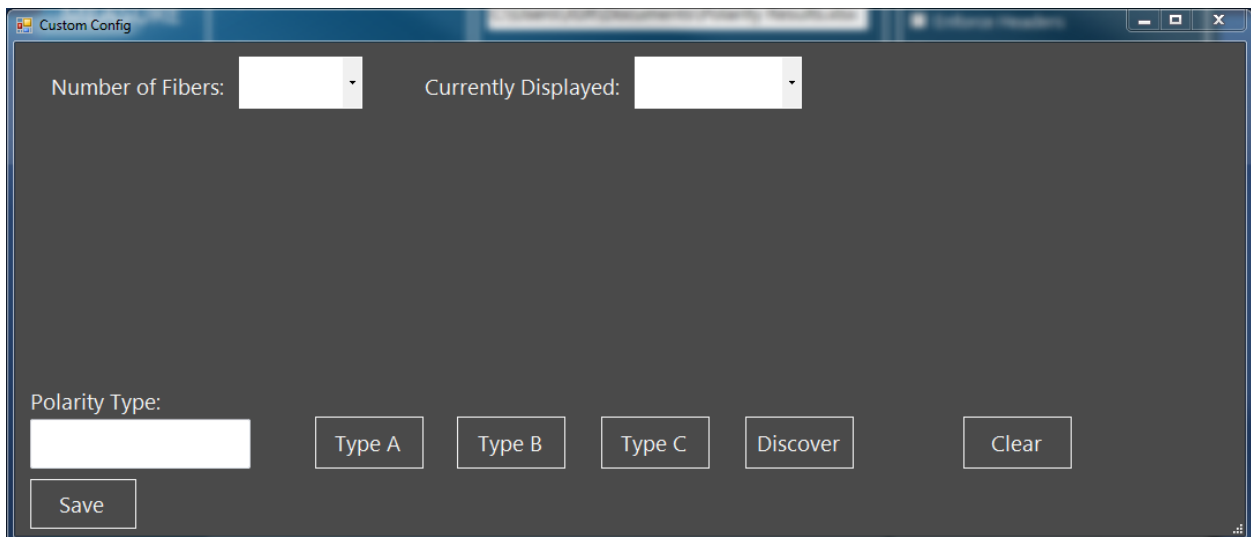
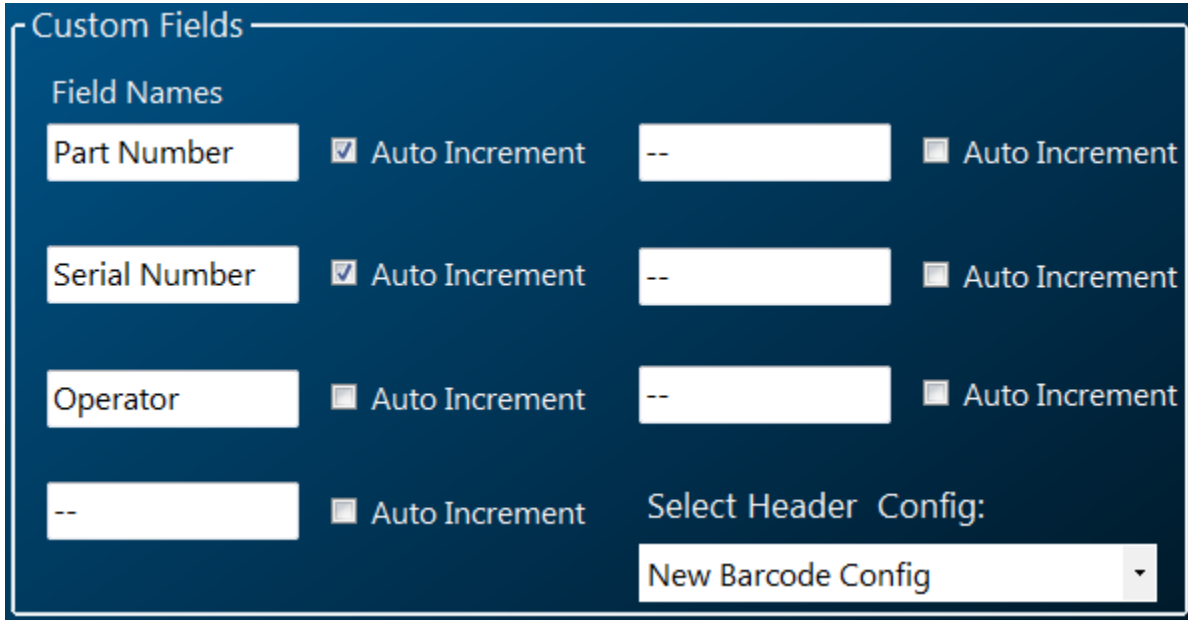

Figure 23: Polarity Test Software – custom polarity configuration window

To define a new polarity type, enter the number of fibers, the name of the polarity type and for each output, enter the expected input fiber.

Custom Fields

Figure 24 allows you to define the headers of the custom fields which can be filled from the *MEASURE* tab. Check the *Auto Increment* box to increase the count of the field every time a test is performed. Example: if custom field is ABC123, after a test is performed the software will automatically increment to ABC124.



Custom Fields

Field Names

| | | | |
|---------------|--|-----------------------|---|
| Part Number | <input checked="" type="checkbox"/> Auto Increment | -- | <input type="checkbox"/> Auto Increment |
| Serial Number | <input checked="" type="checkbox"/> Auto Increment | -- | <input type="checkbox"/> Auto Increment |
| Operator | <input type="checkbox"/> Auto Increment | -- | <input type="checkbox"/> Auto Increment |
| -- | <input type="checkbox"/> Auto Increment | Select Header Config: | New Barcode Config |

Figure 24: Polarity Test Software – Custom Fields

8

Programming Guide

Establishing Communication

The PTM follows the *SCPI* (Standard Commands for Programmable Instruments) message-based programming standard. It conforms to the *USBTMC* (USB Test and Measurement) standard.

USB

VISA drivers are required for USB communication.

- Recommended: *Rohde and Schwarz*
 - https://www.rohde-schwarz.com/gr/applications/r-s-visa-application-note_56280-148812.html
- Alternatives: *National Instruments*, *Keysight*, etc.

Ethernet

Each PTM is factory pre-set to use DHCP. To connect the PTM:

- Connect the PTM to the network via an Ethernet cable
- Swipe on the front panel touchscreen to the *Setup* page to view the PTM's IP address

The TCP/IP libraries provided by most operating systems are sufficient.

Note: any *VISA* implementation is capable of controlling the PTM via TCP/IP on port 5025.

Step-by-step Guide

This section will provide a step-by-step programming guide in a *.NET* programming environment such as *C#* or *VB.NET*.

1. Install *VISA* drivers on the development system
2. Connect the PTM via its USB B port to the development system
3. Add a reference to *Ivi.Visa.dll* in your project:

C:\Program Files (x86)\IVI Foundation\VISA\Microsoft.NET\Framework32\v2.0.50727\VISA.NET Shared Components 5.11.0\Ivi.Visa.dll

4. Use the *IVI.Visa.GlobalResourceManager* to find all USB instruments on your system:

```
Public Overrides Function GetAllAddresses() As String()
    Try
        Dim nameList As New List(Of String)
        nameList = GlobalResourceManager.Find("USB?*INSTR")
        Return nameList.ToArray()
    Catch ex As Exception
        Return Nothing
    End Try
End Function
```

5. Open an *IMessageBasedSession* to the desired device using an address from the *nameList* in the previous step:

```
Private visa As IMessageBasedSession

visa = GlobalResourceManager.Open(addr)
```

6. Use the *Write* method to send SCPI commands and the *Read* method to retrieve results:

```
Public Overrides Function Read(ByVal readableOnly As Boolean) As String
    Dim response As String = String.Empty
    response = visa.RawIO.ReadString()
    If response = String.Empty Then
        Throw New Exception("Read from device failed")
    End If
    Return response
End Function

Public Overrides Sub Write(ByVal strCommand As String)
    visa.RawIO.Write(strCommand)
End Sub
```

Write commands require termination with the linefeed character `\n`.

Note

The PTM runs SCPI commands asynchronously. To check if an operation is complete, it is required to poll the status bit via the query `"STAT:OPER:COND?"`. If the return value is 0, the PTM has completed its operation.

```
Try
    Write("Test:Res?" + vbCrLf)

    While (iResponse <> 0)
        strPolarityResponse = Query(":STAT:OPER:COND?" + vbCrLf)

        If Not Integer.TryParse(strPolarityResponse, iResponse) Then
            iResponse = -1
        End if

        System.Threading.Thread.Sleep(10)

        iCycles += 1
    End While
```

```

        If iCycles > 300 Then
            Throw New System.TimeoutException("Polarity Tester did not
            complete its operation")
        End If
    End While
Catch ex As Exception
    MsgBox(ex.Message)
End Try

```

Commands Lists





See Table 7 and Table 8 for SCPI required and PTM commands respectively.

Table 7: Standard SCPI required commands list

| |
|---|
| *CLS |
| *ESE # |
| *ESE? |
| *ESR? |
| *IDN? |
| *OPC |
| *OPC? |
| *OPT? |
| *RCL "filename" |
| *RST |
| *SAV "filename" |
| *SRE # |
| *SRE? |
| *STB? |
| *TST? |
| *WAI |
| :STATus:OPERation:CONDition? |
| :STATus:OPERation:ENABle <byte> |
| :STATus:OPERation:ENABle? |
| :STATus:OPERation[:EVENT]? |
| :STATus:QUEStionable:CONDition? |
| :STATus:QUEStionable:ENABle <byte> |
| :STATus:QUEStionable:ENABle? |
| :STATus:QUEStionable[:EVENT]? |
| :STATus:PRESet |
| :SYSTem:ERRor[:NEXT]? |
| :SYSTem:VERSion? |
| :SYSTem:COMMunicate:LAN:ADDRes <ip/dhcp> |
| :SYSTem:COMMunicate:LAN:ADDRes? |
| :SYSTem:COMMunicate:LAN:GATEWay <gateway> |

| |
|---|
| :SYSTem:COMMunicate:LAN:GATEway? |
| :SYSTem:COMMunicate:LAN:MASK <netmask> |
| :SYSTem:COMMunicate:LAN:MASK? |
| :SYSTem:COMMunicate:LAN:HOSTname <hostname> |
| :SYSTem:COMMunicate:LAN:HOSTname? |
| :SYSTem:COMMunicate:LAN:MAC? |

Table 8: PTM commands list

| Command | Description |
|-----------------------|--|
| READ:BARCode? | Return a string with the contents of the last barcode scanned. |
| TEST:NOTIFY# "string" | Push a <notification> to the PTM touchscreen display. # indicates the icon to be displayed: <ul style="list-style-type: none"> • 0 =  • 1 =  • 2 =  • 3 =  |
| LCL # | Set local interaction mode: <1> (enabled) or <0> (disabled). |
| LCL? | Return local interaction mode status. |
| LAS:OFF | Turn off all lasers. |
| VFL# | Enter VFL mode and enable output #. |
| FVFL# | Enter VFL in flashing mode: flash output #. |
| CHANnel? | Return # of available output channels. |
| DETECT#? | Turn on laser # and return brightest detector. |
| TEST:CON# | Perform a polarity test on the first # of output channels. |
| TEST:RESult? | Return a list of results. |
| TEST:START | With an XN1 test plan loaded, start a test. |
| TEST:STatus? | Return PASS or FAIL result from last TEST:START operation. |
| TEST:NEXT | After performing an XN1 test plan, save results to server and prepare for the next DUT. |
| TEST:RETRY | After performing an XN1 test plan, retry the current plan. |

9

Maintenance

Warning



- Devices with malfunctioning lasers must be returned to the manufacturer for repair.

Cleaning the Unit

1. Unplug the unit from the line power.
2. Clean the enclosure with a damp cloth.
3. Do not plug the unit back in until it is completely dry.

Cleaning the Output and Receive Connectors

1. Use a bulkhead inspection probe to inspect the output and receive connector end-faces for contamination.
2. If needed, use an MTP/MPO in-bulkhead cleaning device.

10

Storage and Shipping

Damage can occur from improper handling. Make sure to maintain the unit within the specified temperature range during storage or shipping. Please follow the recommendations below to minimize the possibility of damage:

- If possible, pack the unit in its original packing material when shipping.
- Avoid high humidity or large temperature fluctuations that could generate condensation within the unit.
- Avoid unnecessary shocks and vibrations.

Returning Instruments to Santec

As indicated above, please ship the returned material in the original shipping box and packing material. If these are not available, follow the guidelines below:

1. Contact Santec to obtain an RMA number.
2. Cover the front panel with foam to prevent damage.
3. Wrap the unit in anti-static packaging. Use anti-static connector covers.
4. Pack the unit in a strong enough shipping box considering the unit's weight.
5. Use enough shock-absorbing material (10 to 15 cm) to cushion the unit and prevent it from moving inside the box. Pink poly anti-static foam is recommended.
6. Seal the shipping box securely.
7. Clearly mark FRAGILE on at least 3 of the 4 sides of the box.
8. Always provide the model and serial number of the unit and, if applicable, the RMA number on any accompanying documentation. If possible, indicate the RMA number on the box itself to facilitate identification.

Contact Information

Santec Inc.
160 Michael Cowpland Drive
Ottawa, Ontario, Canada
K2M 1P6

Phone: +1-613-599-1000
Fax: +1-613-599-1099
Email: info@jgoptics.com
Website : www.jgoptics.com

11

Specifications

Table 9: PTM optical and electrical specifications sheet

| Parameter | Specification | |
|----------------------------|---------------------------------------|----------------------------|
| Operating Wavelength (nm) | 650 | |
| Laser Class | 2 | |
| Optics Interface | Output | 12 fiber MTP/APC Male (SM) |
| | Receive | 12 fiber MTP/PC Male (MM) |
| Remote Interface | USB / Ethernet | |
| Detected Polarities | A, B, C and unlimited custom mappings | |
| Test Time (s) ¹ | < 2 | |
| IL Tolerance (dB) | < 6 | |
| Input Voltage | 100 to 240 V AC, 50 to 60 Hz | |
| Power Consumption (VA) | 80 maximum | |
| Display | 5" (13 cm) touchscreen | |

Notes:

¹ for 12 channels

Table 10: PTM mechanical and environmental specifications sheet

| Parameter | Specification | |
|--|------------------------------------|------------------------------------|
| | 12-48 Channels | 60 – 288 Channels |
| Unit Dimensions W x H x D (cm) | 23.5 x 12 x 32.5 (2U half rack) | 48.5 x 44.5 x 13 (3U full rack) |
| Shipping Box Dimensions W x H x D (cm) | 36.5 x 39 x 53 | 65 x 58 x 33 |
| Unit Weight (kg) | 3 | 7 |
| Total Shipment Weight (kg) | 4 | 8 |
| Operating Temperature (°C) | 0 to 40 | |
| Storage Temperature (°C) | -40 to 60 | |
| Humidity (Non-condensing) | Max 95% RH from 0 to 40°C | |



In the event of any trouble with this product, turn the unit off in accordance with the procedures to shut off the power described in this operation manual, disconnect the power source cord, make sure the product name and serial number described on the name plate of the product, and then contact our dealer at your place or directly contact us at Santec Photonics Laboratories. Our telephone number and facsimile number are shown below. However, we are not responsible for any trouble arising from your own repair or modification on this product.

SANTEC CORPORATION

5823 Ohkusa-Nenjyozaka, Komaki, Aichi, 485-0802, JAPAN
Tel. +81-568-79-1959
Fax +81-568-79-1718

SANTEC U.S.A. CORPORATION

Continental Plaza II, 433 Hackensack Ave., Hackensack, NJ, 07601, U.S.A.
Tel. +1-201-488-5505 (santec-1)
Fax +1-201-488-7702

SANTEC EUROPE LIMITED

Magdalen Centre, Robert Robinson Ave., The Oxford Science Park, Oxford OX4 4GA, U.K.
Tel. +44-1865-784960
Fax +44-1865-784961

SANTEC (SHANGHAI) CORPORATION, LIMITED

Shanghai Industrial Investment Building 18C, 18 Cao Xi Road (N), Shanghai 200030, P.R. China
Tel. +86-21-64279089
Fax +86-21-64279087

SANTEC CALIFORNIA CORPORATION

4750 Calle Quetzal, Camarillo, CA, 93012, U.S.A.
Tel. +1-805-987-1700

SANTEC CANADA CORPORATION

160 Michael Cowpland Drive, Ottawa, Canada, K2M 1P6
Tel. +1-613-599-1000

www.santec.com email:info@santec.com